



DESCRIPTION

The Model 501K-1 is a **Manual Engine Control Module**, which has been designed to manually control the engine via a key switch on the front panel. The module is used to start and stop the engine, indicating fault conditions; automatically shutting down the engine and indicating the engine failure by LED giving true first up fault annunciation.

Operation of the module is via a three position key switch mounted on the front panel with STOP(O), RUN(I) and START(II) positions. In the 'O' position the DC supply is removed from the module and the run relay and alarm output are de-energised. If the switch is turned to the 'I' position the module is powered up and the run relay is energised, activating the engine fuel/ignition system and the protection hold-off timer is initiated. If the switch is moved to the 'II' position and held against the spring return, a positive supply is applied to the relevant output terminal and on to the starter motor. Once the engine has started the switch should be released and allowed to return to the 'I' position.

Operation of any of the following alarms; **Low Oil Pressure, High Engine Temperature, Auxiliary Shutdown, Overspeed (Optional)**, will cause the run relay to de-energise. This will remove the fuel/ignition supply from the engine and bring it to rest. The alarm output will be activated giving a positive DC output.

Each alarm channel has its own LED indicator and once activated no further alarm conditions will be accepted. The alarm output and relevant LED will remain active until the unit is reset by turning the switch to the 'O' position.

Overspeed Protection (Optional) is achieved by the fitment of an additional PCB in the module. This provides integral overspeed protection derived from either the generator HZ output or the engine magnetic pick-up (*specified on ordering*). The overspeed circuit continuously monitors the engine speed and will shut down the engine immediately if a pre-set speed level is exceeded. This trip level is adjustable from 90% to 130% of full rated speed and is suitable of both 50Hz or 60Hz systems.

During engine cranking and for a short time afterwards the **protection hold-off timer** is active and the relevant alarms inputs are inhibited. This enables the engine to start and achieve normal running conditions. Once the timer has expired the inputs are enabled providing normal protection from the module.

Charge Failure warning is also provided by monitoring the WL terminal on the charge alternator. This operates on a similar principal to the warning lamp fitted in a motor vehicle, should the output fail the charge fail LED will illuminate. The module will also provide the alternator excitation current via this connection.



SPECIFICATION

DC Supply:

9 to 33 V Continuous.

Cranking Dropouts:Able to survive voltage dips during cranking. *This is achieved without the need for internal batteries.***Alternator Input Range:**

15 - 305 V AC RMS

Alternator Input Frequency:

50 - 60 Hz at rated engine speed.

Magnetic Input Range:

0.5 V to +/- 80 V

Magnetic Input**Frequency:** 2300Hz to 6000 Hz at rated engine speed.**Start Relay Output:**

16 Amp DC at supply voltage.

Run Relay Output:

16 Amp DC at supply voltage.

Alarm Output:

1 Amp DC at supply voltage.

Dimensions:

72 X 72 X 118.5 (Excluding Key-switch)

Operating Temperature Range:

-30 to +70°C

Installation:

Front panel mounting via suitable cut-out. Retaining clips supplied. Cable connections via locking plug and socket type connectors.

Calibration:

Speed trip setting and meter calibration adjustment potentiometer are accessible from the rear of the module.

CASE DIMENSIONS

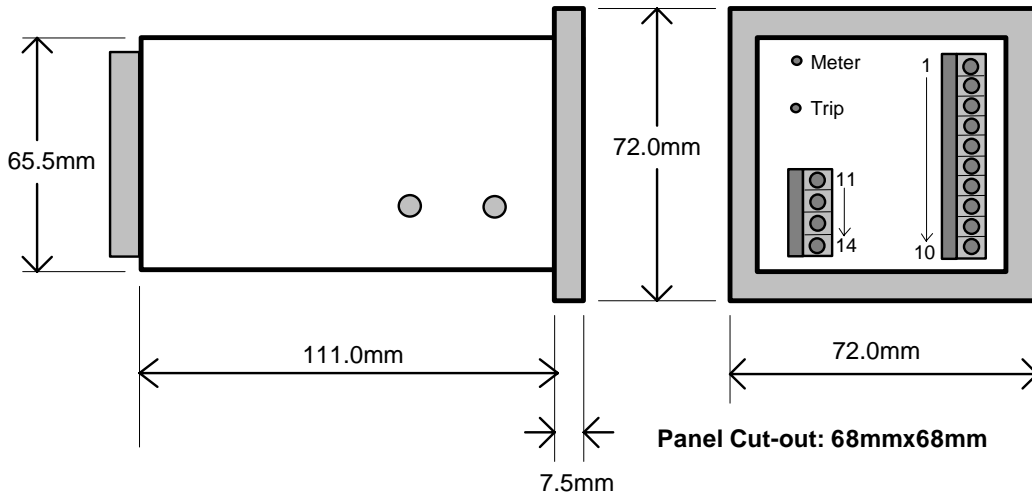

TYPICAL CONNECTIONS

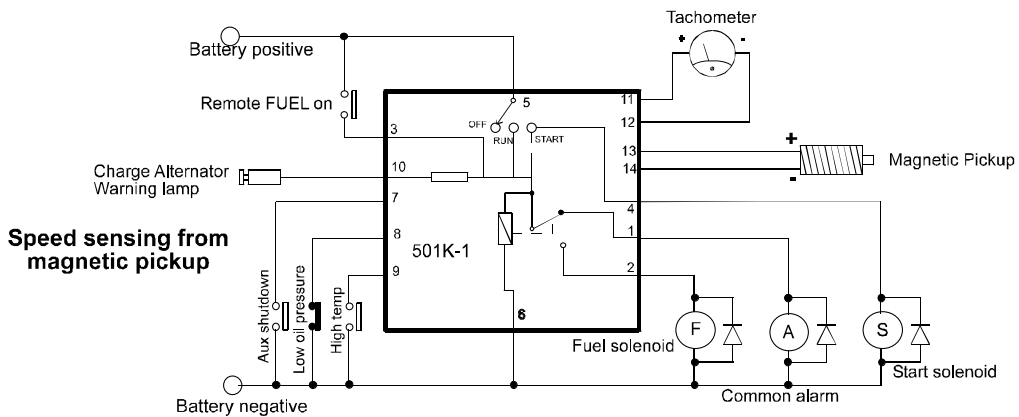
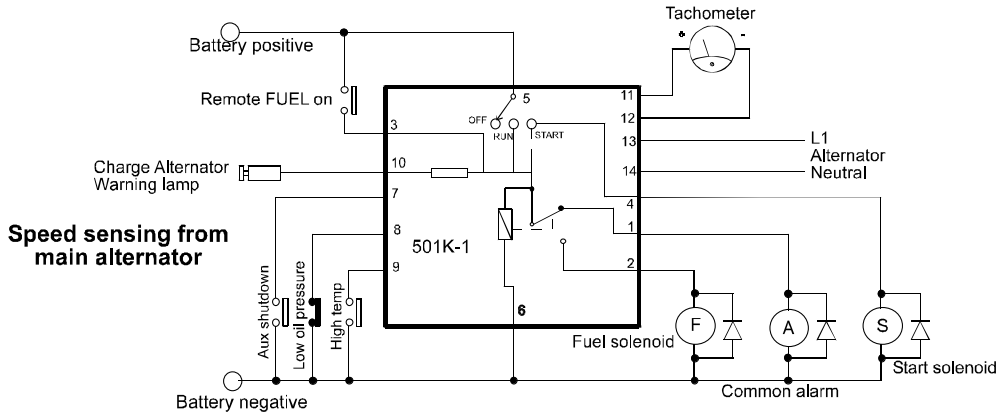
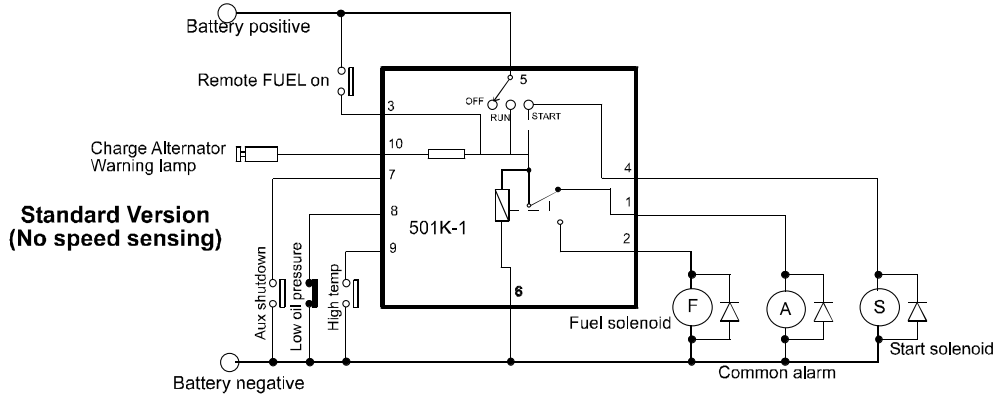

Deep Sea Electronics plc

Highfield House, Hunmanby Industrial Estate, North Yorkshire, YO14 0PH, England
 Tel: +44 (0) 1723 890099 Fax: +44 (0) 1723 893303 E-mail sales@deepseapl.com