



DESCRIPTION

The Model 5110 is an **Automatic Engine Control Module**. The module is used to automatically start and stop the engine, indicating the operational status and fault conditions, automatically shutting down the engine and indicating the engine failure by means of a graphical LCD display and a flashing LED on the front panel. Selected operational timers and alarms can be altered by the customer. Adjustments are made by using the integral front panel editor allowing changes in the field, with no specialist equipment required.

Operation of the module is via pushbuttons mounted on the front panel with STOP, AUTO and MANUAL modes.

A further pushbutton provides an LCD DISPLAY SCROLL function to view the instrumentation.

The module features microprocessor control and provides a comprehensive list of timers and pre-configured sequences. This allows complex specifications to be achieved.

Multiple alarm channels are provided to monitor for the following conditions:

- ▶ Under/Overspeed
- ▶ Charge alternator failure
- ▶ Emergency stop
- ▶ Low oil pressure
- ▶ High engine temperature
- ▶ Fail to start (overcrank)
- ▶ Fail to come to rest
- ▶ Loss of speed sensing signal

Additionally any configurable input alarms that have been configured as indication, warning or shutdown. Alarms are indicated by an LCD Icon and LED illumination.

The 5110 series modules have been designed for **front panel mounting**. The module is fitted into the cut-out with the fixing clips removed. These are then fitted from the rear. Connection is via locking plug and socket connectors.

The 5110 module provides engine and electrical **metering facilities** via the LCD display with the following instrumentation displays, accessed via the SCROLL push-button:

Generator Volts L1-N, L2-N, L3-N
Generator Volts L1-L2, L2-L3, L3-L1
Generator Amps L1, L2, L3
Generator Frequency Hz
Engine Speed RPM
Engine Oil Pressure (PSI & Bar)
Engine Temperature (°C & °F)
Plant Battery Volts
Engine Hours Run

e.g.

| | | |
|-------|-------|-------|
| L1-L2 | L2-L3 | L3-L1 |
| 420 | 391 | ~ V |
| | | 405 |

The instrumentation displays are supplemented further by **LCD icon displays for various engine alarms**.

Uncommitted LCD icons allow the user to configure the module to provide other status or alarm indications from either internal states or from external digital inputs.

The module accepts the following **digital inputs**:

- ▶ Emergency Stop - A N/C DC positive input
- ▶ 5 fully configurable warning or shutdown inputs.

With the exception of the Emergency Stop Input, these are configurable to be either N/C or N/O contacts, switched to the -Ve DC.

The five fully configurable auxiliary inputs can be selected to be indication, warning or shutdown inputs either immediate or held off during start up to allow for use as protection expansion inputs. Alternatively they may be configured to control extra functions such as lamp test or Remote start input - refer to appropriate manuals for details.



DESCRIPTION (continued)

Engine **analoge inputs** are provided for Oil Pressure and Engine Temperature. These connect to conventional engine mounted resistive sender units (such as VDO or Datcon Type) to provide accurate monitoring and protection facilities. Alternatively they can be configured to interface with digital switch type inputs for Low oil pressure and high engine temperature shutdowns.

Relay outputs are provided for Fuel Solenoid Output, Start Output and three configurable outputs.

A range of different functions, conditions or alarms can be selected for the three configurable relay outputs. These outputs supply positive plant supply out.

Refer to appropriate manuals for details.

FEATURES

- ▶ Micro-processor based design
- ▶ Automatic engine starting and stopping
- ▶ Automatic shutdown on fault condition
- ▶ Custom graphical icon type display
- ▶ Provides engine and generator instrumentation
- ▶ Provides engine alarms alarm and status information
- ▶ "Front panel" configurable inputs, outputs, alarms and timers.
- ▶ LED & LCD alarm indication
- ▶ Compatible with 5200 series modules for easy upgrade path.

SPECIFICATION

DC Supply:

8 to 35 V Continuous.

Cranking Dropouts:

Able to survive 0 V for 50mS, providing supply was at least 10V before dropout and supply recovers to 5V. *This is achieved without the need for internal batteries.*

Start Relay Output:

10 Amp DC at supply voltage.

Fuel Relay Output:

10 Amp DC at supply voltage.

Auxiliary Relay Outputs:

2 Amp DC at supply voltage.

Charge Fail / Excitation Range:

0 V to 35 V

Operating Temperature Range:

-30 to +70°C

Environment

Pollution Degree 2

Overtoltage Category III

Max. Operating Current:

420mA at 12V, 270mA at 24V

Max. Standby Current:

250mA at 12V, 140mA at 24V

Alternator Input Range:

75(ph-N) to 277(ph-N) 3 Phase 4wire AC (+20%)

Alternator Input Frequency:

50 - 60 Hz at rated engine speed (Minimum: 15V AC Ph-N)

Magnetic Pick-up Voltage Input Range:

+/- 0.5 V to 70 V Peak

Magnetic Input Frequency: 10,000 Hz (max) at rated engine speed.

Dimensions:

240mm x 172mm x 57mm (9½" x 6¾" x 2¼")

Panel Cutout:

220mm x 160mm (8.7" x 6.3")

Maximum Panel Thickness:

8mm (0.31")

Deep Sea Electronics plc reserve the right to change specification without notice.

TYPICAL WIRING DIAGRAM

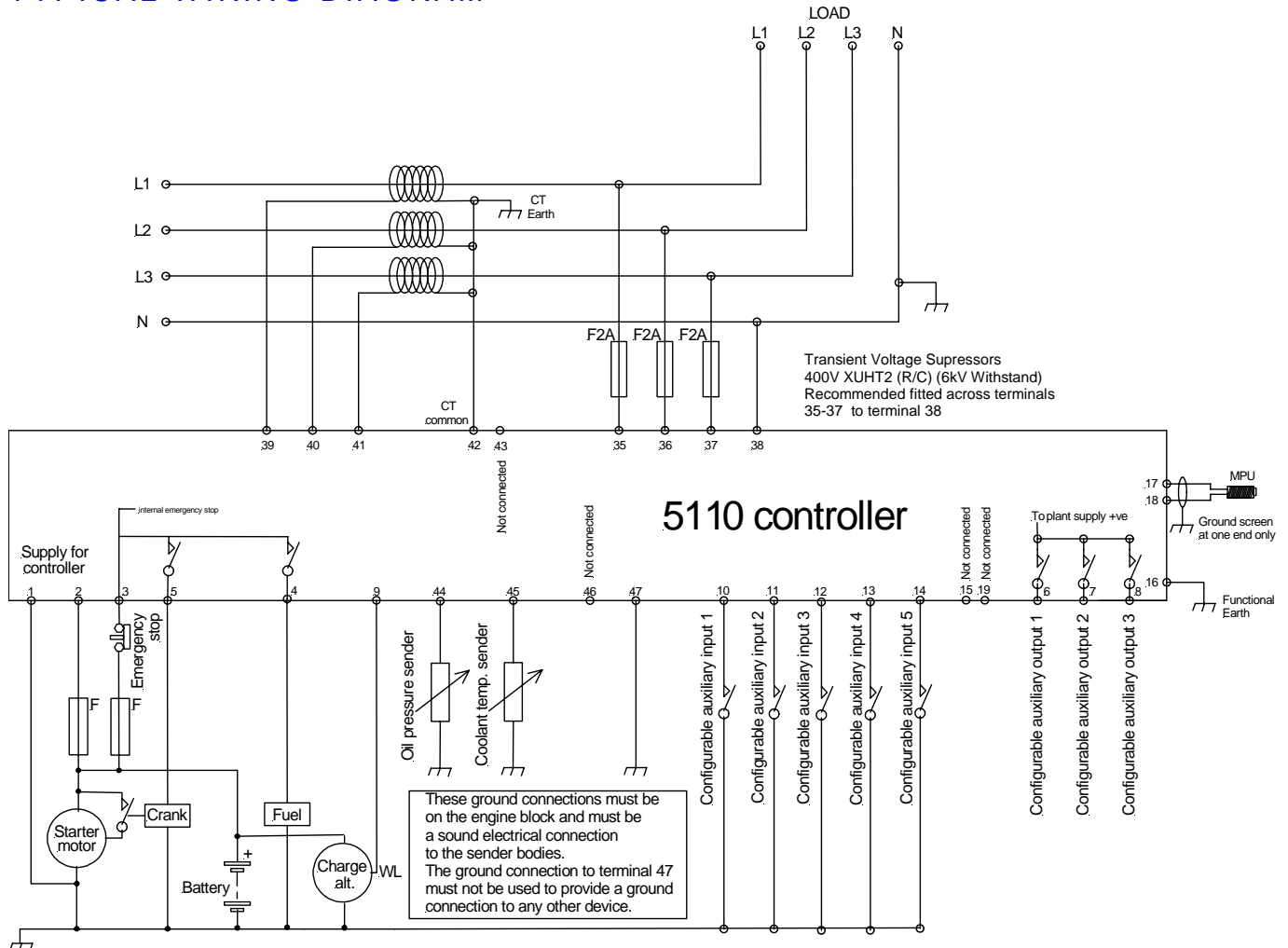

Deep Sea Electronics Plc.

Highfield House, Hunmanby Industrial Estate,
North Yorkshire. YO14 0PH. ENGLAND

Tel +44 (0)1723 890099.

Fax +44 (0)1723 893303.

Email - sales@deepseapl.com

Web - www.deepseapl.com

Deep Sea Electronics inc.

5301 E. State St. – Suite 202
Rockford, Illinois 61108 U.S.A.

Phone +1 (815) 316-8706

Fax +1 (815) 316-8708

Email – dsales@deepseausa.com

Web – www.deepseausa.com