



FEATURES

- **Comprehensive remote communication via optional RS232 port. Provides RS232 Modem link to PC via either PSTN line or GSM network (using a suitable modem). The module can also signal Engineers via their cell phones using the GSM SMS messaging system to advise of system alarms.**
- **Optional RS485 'Modbus' output. Using industry standard communication protocol allows full system integration into new and existing building management and control schemes.**
- **Module provides a number of control and monitoring features with expansion capabilities to meet with more demanding specifications. The ideal choice where a remote communications control system is specified (when used with one of the comms output options above).**
- **Power measurement is included in the comprehensive specification (detailed right).**
- **Clear icon based language free display provides access to full gen-set instrumentation**
- **Hid-til-lit SMD LED technology is utilised to provide at a glance diagnosis of fault conditions and operating state.**
- **Front panel programming of trip points and timers, allows field changes to be made to the module settings.**

The 5200 series modules have been designed for **front panel mounting**. The module is fitted into the cut-out with the fixing clips removed. These are then fitted from the rear. Connection is via locking plug and socket connectors.

DESCRIPTION

The Model 5210 is an *Automatic Engine Control Module*. The module is used to automatically start and stop the engine, indicating the operational status and fault conditions, automatically shutting down the engine and indicating the engine failure by means of an LCD display and a appropriate flashing LED on the front panel. Selected timers and alarms can be altered by the customer from the front panel. Alterations to the system are made using the 810 interface and a PC. This interface also provides real time diagnostic facilities.

It is also possible to monitor the operation of the system either locally or remotely. (Optional: Remote Communications output versions only).

Easy pushbutton control

Operation of the module is via pushbutton controls (with security locking facility) mounted on the front panel with STOP/RESET, AUTO, MANUAL and START pushbutton. The first three pushbuttons feature LED 'selected' indications. Further pushbuttons provide LCD DISPLAY SCROLL and EVENT LOG VIEW functions.

Microprocessor control

The module features 16-Bit microprocessor control and a comprehensive list of timers and pre-configured sequences. This allows demanding specifications to be achieved. Configurable expansion facilities are also provided .

Metering

The 5210 module provides metering via the LCD display with the following instrumentation displays, accessed via the LCD DISPLAY SCROLL push-buttons:

Generator Volts L1-N, L2-N, L3-N
 Generator Volts L1-L2, L2-L3, L3-L1
 Generator Amps L1,L2,L3
 Generator Frequency Hz
 Engine Speed RPM
 Engine Oil Pressure
 Fuel Level %
 Engine Temperature
 Plant battery Volts
 Engine Hours Run
 Generator kVA
 Generator kW
 Generator Cos θ

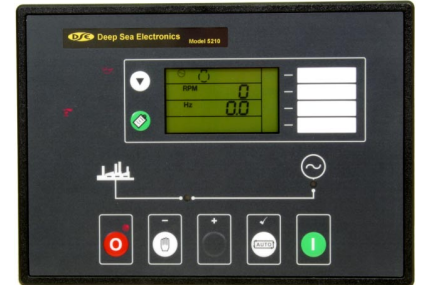

Event Log

The instrumentation displays are supplemented further by EVENT LOG VIEW, which shows the last 15 shutdown events along with date and time of shutdown.

LED indication

'Hid-'til-'lit' icons are used to show the presence of alarm conditions detected by the module.

In addition 4 uncommitted LCD segments allow the user to configure the module to provide other status indications from either internal states or from external digital inputs.

Digital Inputs

The module accepts the following digital inputs:
 Emergency Stop Input - A N/C DC positive input
 Fully configurable warning or shutdown inputs
 With the exception of the Emergency Stop Input, these are configurable to be either N/C or N/O contacts connected to the -Ve DC. The 6 fully configurable auxiliary inputs can be selected to be indication, warning or shutdown inputs either immediate or held off during start up to allow for use as protection expansion inputs. Alternatively they may be configured to control extra functions such as Lamp Test or Remote Start input, and many others - refer to appropriate manuals for details.

Description continues overleaf...

DESCRIPTION

Continued

Analogue inputs

Provided for Oil Pressure, Engine Temperature and Fuel Level. These connect to conventional engine mounted resistive sender units (such as VDO or Datcon Type) to provide accurate monitoring and protection facilities. Alternatively they can be configured to interface with digital switch type inputs for Low Oil Pressure and High Engine Temperature shutdowns. Fuel level gauge provides a low fuel level alarm, and transfer pump control logic.

Relay outputs

Provided for Fuel Solenoid Output, Start Output and three configurable outputs. The configurable relay functions can be selected from a range of different functions, conditions or alarms. The relays supply positive plant supply out. Additional output relays can be added by means of a 157 Relay Expansion Module. A total of 11 outputs are available with full expansion of the 5210 Module. This allows the module system to be incorporated into existing telemetry or Building Management Schemes via Volt-free contacts. Refer to appropriate manuals for details.

Multiple alarm channels

Provided to monitor the following:

- Under/Over Generator Volts
- Over-current
- Under/Over Generator Frequency
- Under/Overspeed
- Charge Fail
- Emergency Stop
- Low oil pressure
- High engine temperature
- Fail to Stop
- Fail to Start
- Low/High DC Battery Volts
- Low Fuel Alarm
- Loss of speed sensing signal

SPECIFICATION

DC Supply:

8 to 35 V Continuous.

Cranking Dropouts:

Able to survive 0 V for 50 mS, providing supply was at least 10 V before dropout and supply recovers to 5V. *This is achieved without the need for internal batteries.*

Max. Operating Current:

425mA at 12 V & 215mA at 24 V.

Max. Standby Current:

250 mA at 12 V & 125 mA at 24 V.

Alternator Input Range:

75V(ph-N) to 277V(ph-N) AC (+20%)

Alternator Input Frequency:

50 - 60 Hz at rated engine speed
(Minimum: 15V AC Ph-N)

Magnetic Pick-up Voltage Input Range:

+/- 0.5 V to 70 V Peak

Magnetic Input Frequency: 10,000 Hz (max)

Start Relay Output:

16 Amp DC at supply voltage.

Fuel Relay Output:

16 Amp DC at supply voltage.

Auxiliary Relay Outputs:

5 Amp DC at supply voltage.

Dimensions:

240mm x 172mm x 57mm
(9½" x 6¾" x 2¼")

Charge Fail / Excitation Range:

0 V to 35 V

Operating Temperature Range:

-30 to +70°C

TIMERS AND INPUT FUNCTIONS

- Start delay timer
- Stop delay timer
- Crank/Crank rest timers
- Engage attempt and manual crank limit timers
- Safety on delay timer
- Warm-up timer
- Cooling timer
- Energise to stop hold timer
- Pre-heat timer / Pre-heat bypass timer
- Smoke limiting control timers
- Fail to stop
- Over-speed overshoot timer
- Breaker pulse control timers
- DC Battery alarm delay timers

NOTE

An Automatic Mains Failure version of the 5210 is also available (Model 5220). This combines all the features of the 5210 coupled with built-in mains monitoring and change-over contactor control. Please refer to Deep Sea Electronics for details.

TELEMETRY

The 52xx Series PC software is MS-Windows™ based and allows the operator to control the module from a remote location.

The remote operator can also view the Instrumentation, Alarm and Event Log details, and the Relay and Input status.

Optional features

The 5210 module can provide the user with full telemetry facilities via the optional communications software. The module can be either connected to the PC using the 810 interface or via a suitable modem.

Remote Communications output version only - RS232 or RS485 available.

In the event of the module detecting an alarm condition, it will initiate a modem dial-out to the host PC informing the remote operator of the problem, giving identification of the module followed by alarm event and time and date of the occurrence.

Remote Communications output version only.

EVENT CAPTURE

To assist in fault-finding etc., the standard module features an Event Capture facility. This records the last 15 shutdown alarms, allowing the operator to view the recent operating history of the module.



Event Log:

CONFIGURATION

PC based configuration software allows for fast, simple and secure configuration of module parameters. Utilising the P810 interface to provide a safe isolated link to the PC, changes can easily be made to the system by authorised personnel.

Complex configurations can be saved and loaded from disk or output to a printer for reference. Diagnostic facilities allow for fault finding and monitoring during test and installation.

Alternatively selected alarm trip points and timers can be adjusted from the front panel buttons.

BUILT-IN FUNCTIONS

- Alternator Under/Over Volts Warning/Shutdown
- Alternator Under/Over Freq. Warning/Shutdown
- Under/Over Speed Warning/Shutdown
- Low Oil Pressure Warning/Shutdown
- High Engine Temp Warning/Shutdown
- High/Low Battery Volts Warning
- Over-current Warning/Electrical Trip/Shutdown
- Adjustable crank cycle/attempts
- External remote start input (On load/Off load)
- Built in Exercise Scheduler
- Magnetic Pick-up or Alternator speed monitoring
- Event Logging of Shutdown Alarms
- Full Remote Control and Telemetry (Option)
- Graphic Icon based LCD Display for true Multi-lingual use
- 6 Digital inputs - Fully user configurable
- 3 Configurable relay outputs
- LCD Back-lighting for low light level operation
- System lock input
- SMS messaging capability with suitable GSM Modem
- Front panel configuration of timers and alarm trip points

ENVIRONMENTAL TESTING STANDARDS

Electromagnetic Compatibility

BS EN 50081-2: 1992 and EN 6100-6-4:2000 EMC Emission Standards for the Industrial Environment

EN 61000-6-2:1999 EMC Immunity Standard for the Industrial Environment

Vibration

BS EN 60068-2-6 Ten sweeps (up and back down) at 1 octave/minute in each of the three major axes.

5Hz to 8 Hz @ +/-7.5mm constant displacement.

8Hz to 500 Hz @ 2gn constant acceleration

Temperature

Cold:

BS EN 60068-2-1-to -30°C

Hot:

BS EN 60068-2-2 to 70°C

Humidity

BS EN 2011 part 2.1 93% RH @ 40°C for 48 hours

Shock

BS EN 60068-2-27 Three half sine shocks in each of the three major axes 15gn amplitude. 11mS duration.

Electrical Safety

BS EN 60950 Low Voltage Directive/Safety of information technology equipment, including electrical business equipment.

CASE DIMENSIONS

Panel cutout 220mm x 160mm (8.7" x 6.3")

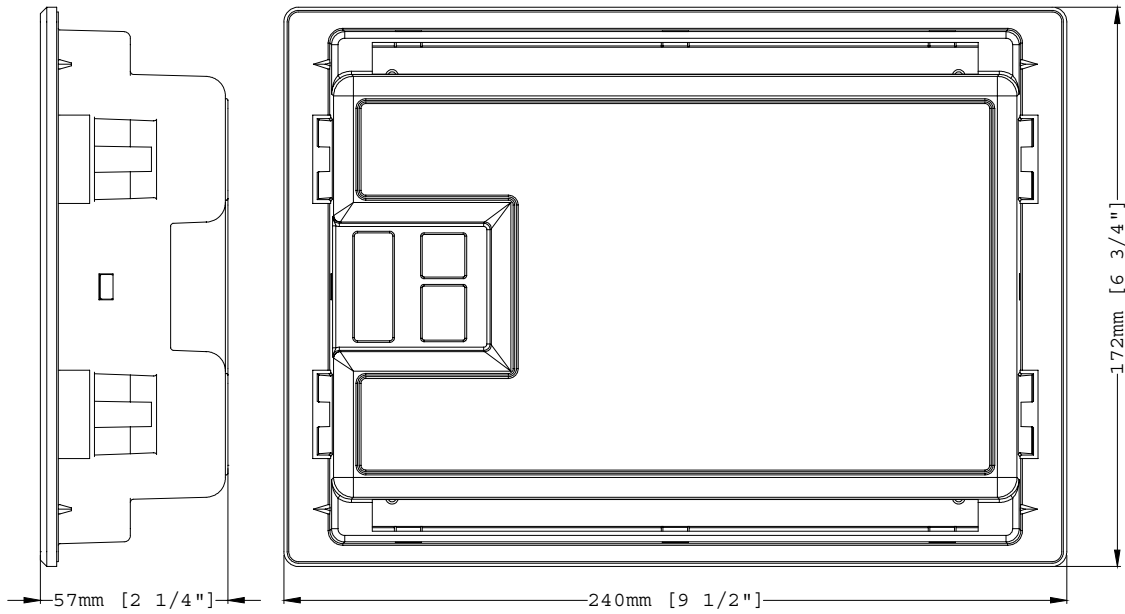

TYPICAL CONNECTIONS

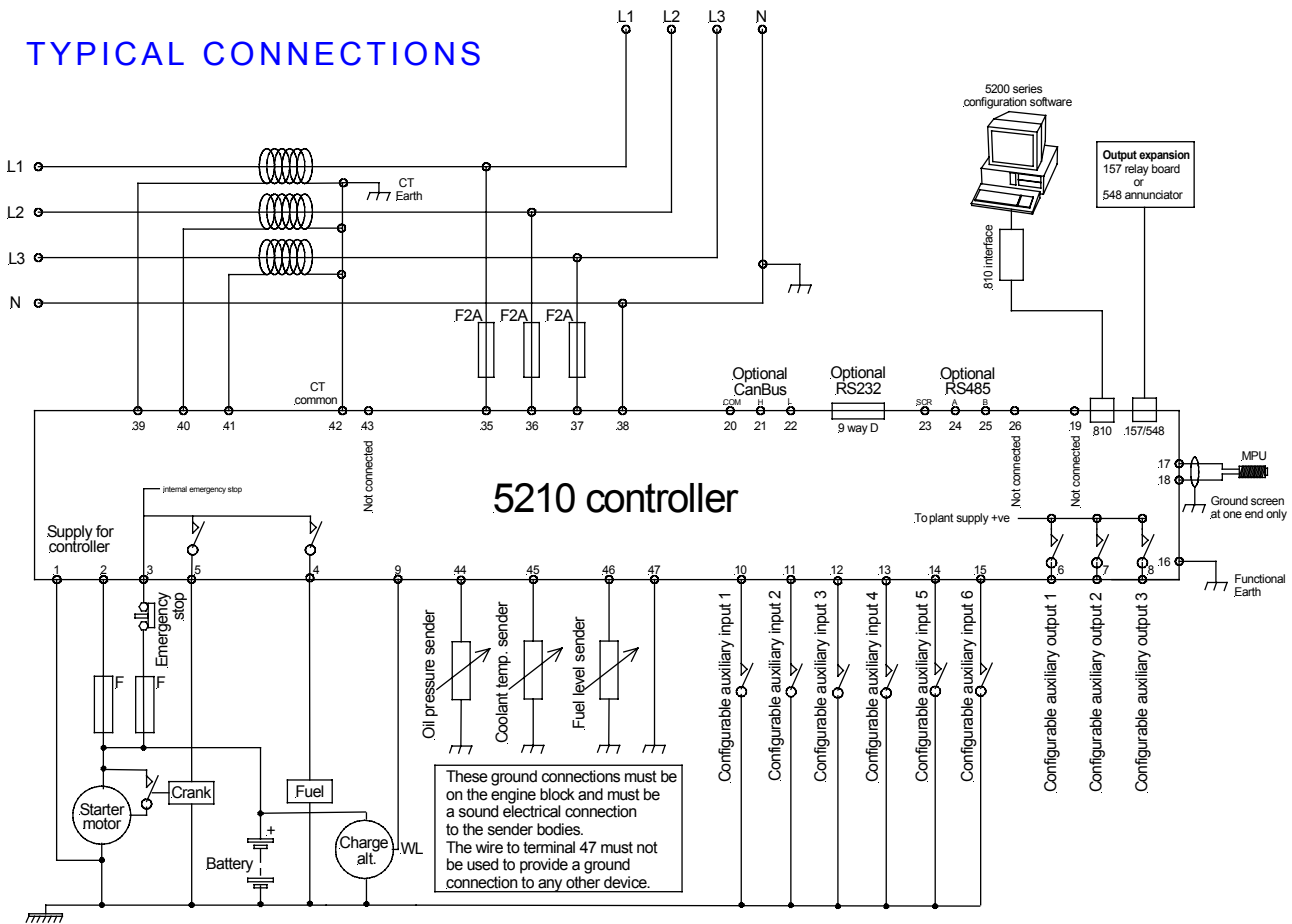

Deep Sea Electronics Plc.
 Highfield House, Hunmanby Industrial Estate, North Yorkshire. YO14 0PH.
 ENGLAND
 Tel: +44 (0)1723 890099.
 Fax: +44 (0)1723 893303.
 Email: sales@deepseapl.com
 Web: www.deepseapl.com

Deep Sea Electronics Inc.
 5301 E. State St. – Suite 202
 Rockford, Illinois 61108
 U.S.A.
 Phone: +1 (815) 316-8706
 Fax: +1 (815) 316-8708
 Email: dsesales@deepseausa.com
 Web: www.deepseausa.com