

IMSAB COMPONENT GUIDE for industry and shipping

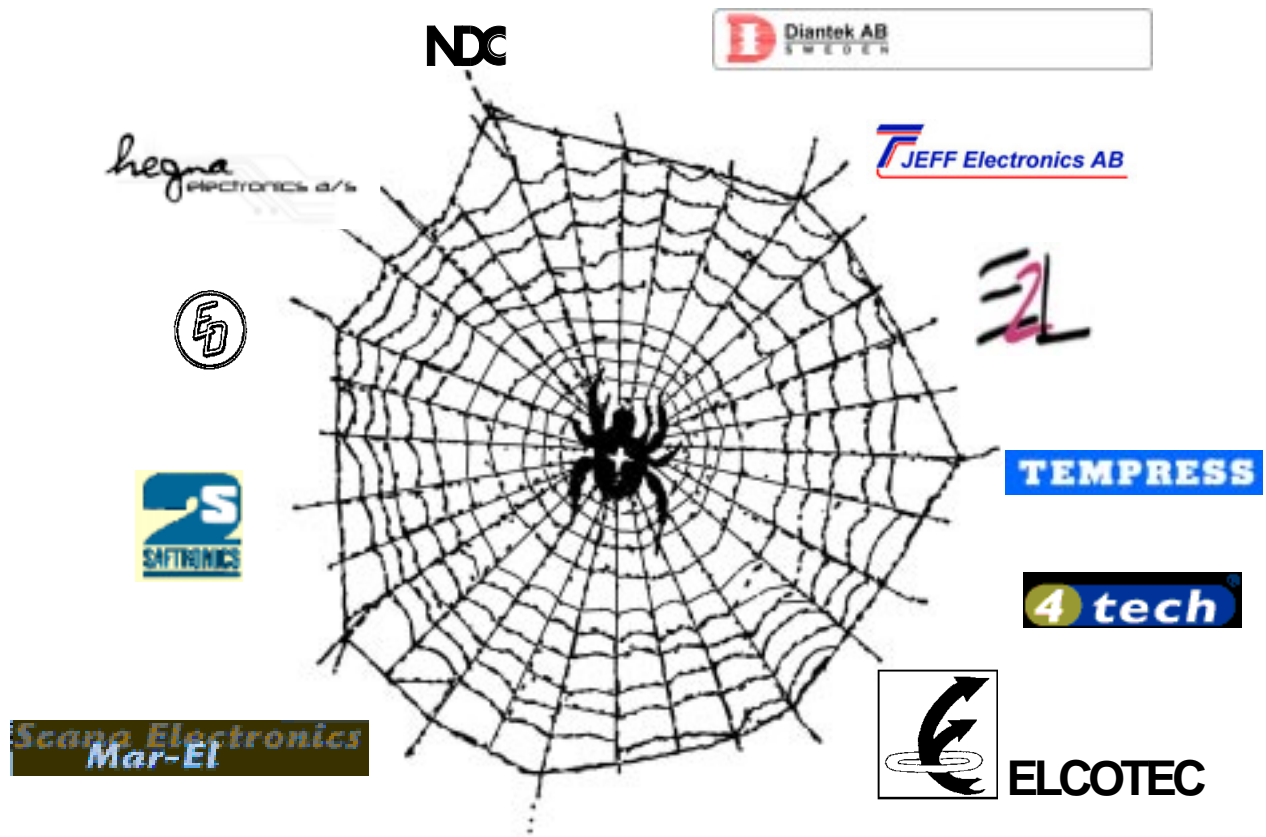

Operation alarm panel LH 10 110VDC



ALARM DISPLAY UNIT LH 10 FOR 110V DC

FOR INDUSTRY AND POWER DISTRIBUTION.



- **10 -channel unit for both normally open and closed sensor contacts (No/Nc)**
- **Two categories of alarm groups (A-B alarm) Time delay for each group.**
- **Memory and flashing light**
- **Voltage failure check**
- **Standard 19" rack width. Two modular height in accordance with DIN standards**
- **SEN R 430117**
- **Certificated in CE-standards EN 50 082-2**

ADVANTAGES AND OPERATION

LH-10 is delivered for use with normally open sensor contacts, but can easily be re-programmed for normally closed sensor contacts, on any chosen alarm channel. The unit is fitted with flashing indicator lights and memory i.e. faults that have returned to their normal state before being accepted / acknowledged are still shown on the panel.

The alarms can be graded into two groups according to the degree of urgency. Each group is provided with a group alarm output and adjustable time-delay. The sensor contacts close (or open) and the corresponding lamp flashes. The memory and the output contacts are activated when the pre-set time for the group has expired. The alarm signal is acknowledged by pressing the red accept button; the flashing lamp becomes steady and the group output contacts return to their normal state. When the fault has been corrected and the sensor has returned to its normal state, the indicator lamp goes out.

Functions test can be done with a push at the BLACK button, which simulate fault at the panel.

Lamp test can be done with a push at the button BLACK + RED button at same time.

Legends can be fitted to the indicator lamps or the screens can be engraved. With LH-10 it is possible to connect a remote accept facility and the unit can be specially equipped for use in unmanned power installations.

SECURITY

LH-10 is designed for severe mechanical and electrical environ-mental conditions. It is provided with protection against polarity reversal and accidental connection of voltage. The unit is designed to indicate voltage failures, each group relay is normally activated. In the alarm state the relay is deactivated and a signal can be given with, for example, a horn. The same happens when the supply voltage is interrupted. Testing for normal function is carried out by pressing the black test button, which simulates faults on the alarm channels of the system.

The unit is in accordance with CE-standards: EN 50 082-2; IEC 801-2:1991; ENV 50 140; ENV 50 141; IEC 801-4

INSTALLATION

The LH-10 is designed for panel mounting into a power cabinet.

LH-10 for use in power installations, is made only in the master version only. The unit is connected through an easily accessible screw terminal block, each fitted with an additional terminal strip (plug and socket). Connection is simple and the terminal arrangement allows the unit to be separated quickly, without disturbing the cable connections.

A selector switch, which can be easily changed on the circuit board of the unit, is used to connect the alarm points to the desired group alarm output (A or B alarms). In the case of normally closed sensor contacts, a wire link in the actual channel circuitry has to be cut off.

SPECIFICATIONS

Supply voltage: 110V DC \pm 20%

Supply current: Normally condition 0,02A
Alarm condition 0,25A.

Time delay: 0,5-20 sec. adjustable common time for each alarm group.

No. of alarm groups: Max 2 per panel (A and B alarms).
Selection device on each alarm channel.

Output contacts: Each alarm group has 1 set of closing contacts. Contact rating 100V, 100VA, resistive load.

Front: Natural colour anodised aluminium

Legends: Film legend 24x32 mm or engraved on lamp



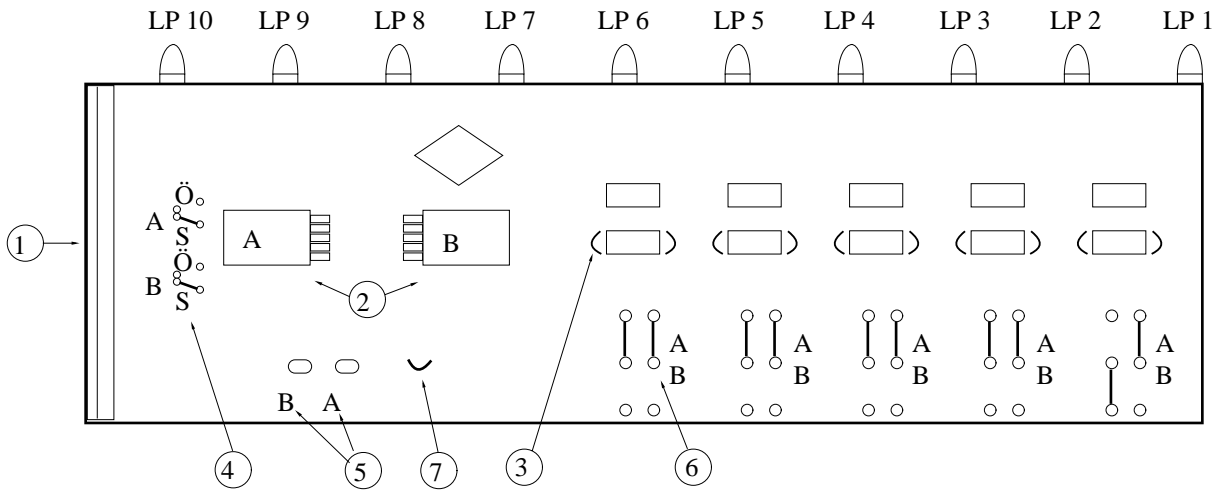
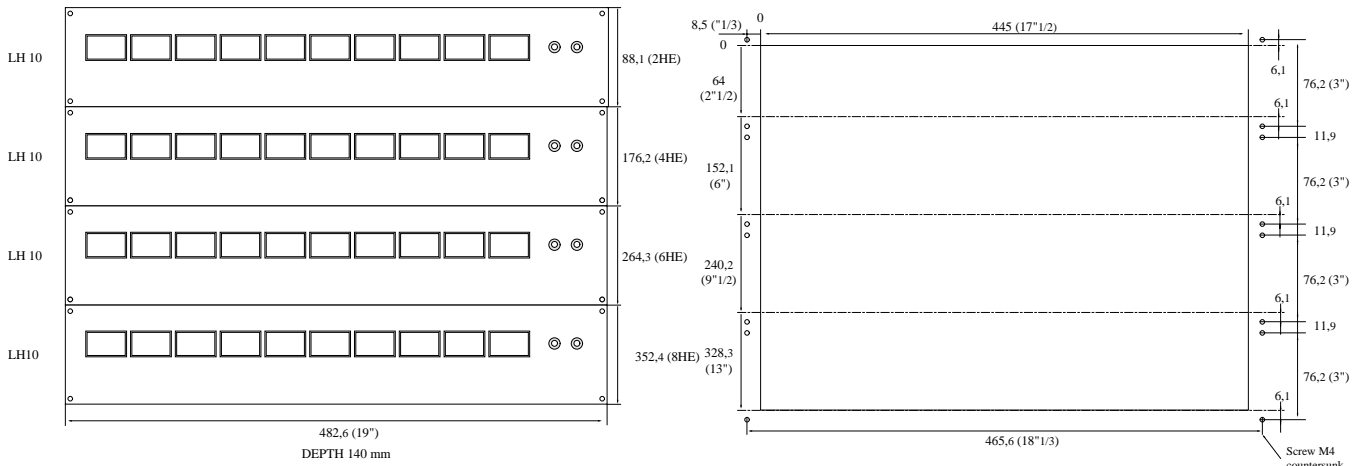

CONNECTION

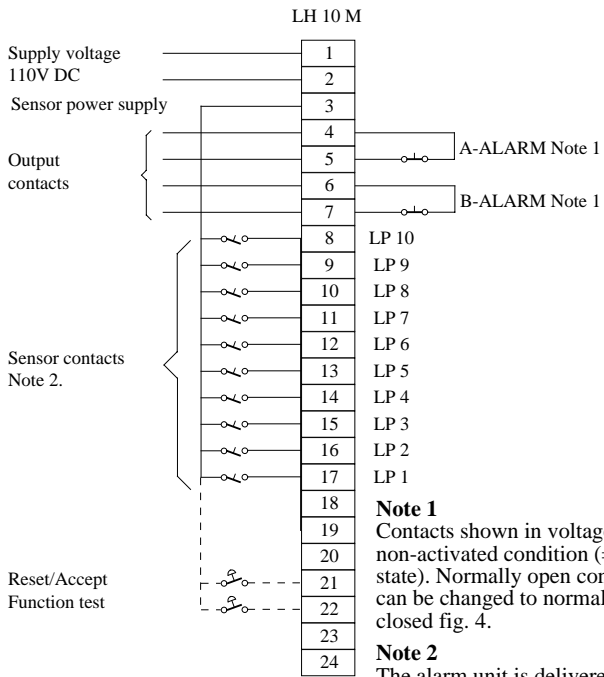

Note 1
 Contacts shown in voltage non-activated condition (=alarm state). Normally open contacts can be changed to normally closed fig. 4.

Note 2
 The alarm unit is delivered for normally open sensor contacts.

screen.
 Lamps: Ba9s 130V 20mA
 Main dimension: 88x482x140 mm
 Panel recess: 64x445 mm
 Max permissible external cable resistance: 5000 ohm.

ORDERING INSTRUCTION

12032 LH 10
 Extra accessories:
 1022 Relay circuit board for an interface to computer or 10 remote alarms.

- ① Terminal block
- ② Output relays
- ③ When normally closed sensor contact (NC) is used this strip is to be cut.
- ④ Reconnection of output contacts.
 S= The output contact will close at alarm and zero voltage.
 Ö= The output contact will open at alarm and zero voltage.
- ⑤ Time delay adjustment
 MIN Ⓞ MAX
- ⑥ Alarm group programming (strap)
 Group A Group B
- ⑦ Time delay for A-alarm:
 Closed strap 0,5-20s.
 Open strap 100ms-2s

