

IMSAB COMPONENT GUIDE for industry and shipping

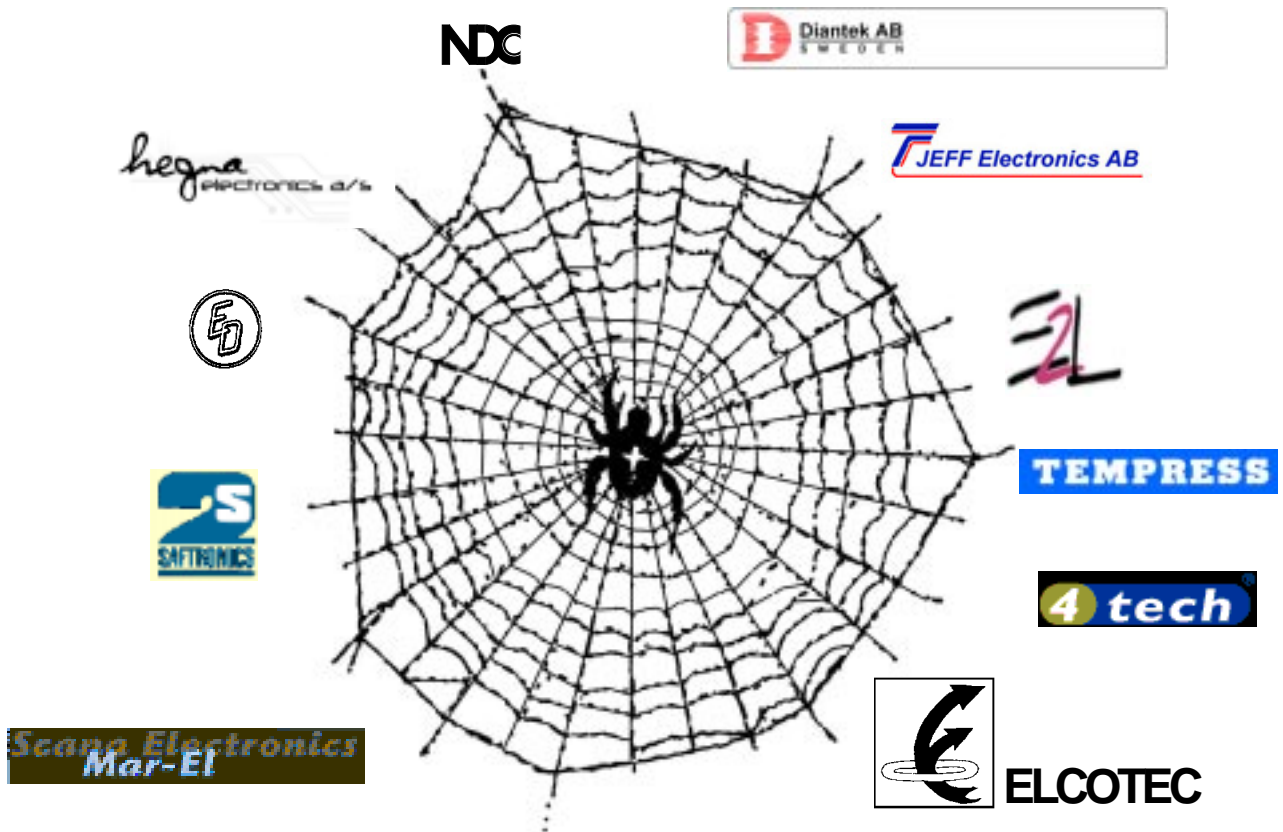

Temperature sensor type P2209



Temperature sensor with clamp connection. P2209

manufacture Tempress



- Pt 1 00 acc. to DIN IEC 751 (DIN 43760)
- Replaceable insert
- Temperature range -50 to +250°C (-58-482°F)
- Unique resistance to corrosion damp, vibrations and wear
- Connection:
3/4", 1 1/2" or 2" clamp (Tri-clamp®) or welding connection
- Sensor tube diameter Ø5
- Immersion length min. 20 mm (0.79")
- Plug with PG 9 cable gland (IP 67)
PTFE cable (IP 68)
DIN form B-head with transmitter (IP 64)
- Transmitter output 4-20 mA

DESIGN

TEMPRESS temperature sensor type P2209 is a standard sensor with stainless steel immersion tube and a welding or clamp connection. 3/4", 1 1/2" and 2" clamp are available.

The 4 wire Pt100 sensor has an accuracy acc. to DIN IEC 751 class B (1/1 DIN).

The electrical connection for the sensor with Pt100 output is a waterproof plug (IP 67) which is screwed onto the sensor or a watertight teflon (PTFE) cable.

The sensor is also available with a head mounted temperature transmitter in a DIN type B head, featuring a 4-20 mA output signal. The measuring range can be factory set or field programmed with a standard DOS PC interface.

The unit is equipped with a replaceable insert, which is unique for sensors with a Ø5 mm immersion tube. This feature makes it possible to weld the sensor to eg. a tube and makes a replacement of the sensor very easy.

The series is employed in all types of industrial and processing plants requiring a hygienic connection.

SPECIFICATIONS

Temperature sensor: Type P2209
 Sensor element: 4-wire Pt100
 Accuracy: DIN IEC 751 Class B
 Sensor tube Material: W.Nr. 1.4571 (AISI 316Ti)
 Diameter: Ø5 mm (.2")
 Length: L.... min. 20 mm (.79")
 Connection Material: W.Nr. 1.4571 (AISI 316Ti)
 Clamp: 3/4", 1 1/2" or 2"
 Welding: Ø12mm
 Surface finish: Standard: Ra <0,8 µm (<32µ")
 Optional: Ra <0.5 µm (<20µ")
 Neck Material: AISI 316
 Dimensions: Ø12 mm (.47") x 35 mm (1,38")
 P2209 Plug type: IEC 947-5-2, 4-wire
 (Pt 100 output) PG 9, IP 67
 Cable type: 2 m 4-wire PTFE insulated
 IP 68
 Measuring range: -50 to +250°C (-58 to +482°F)
 Ambient temperature: -25 to +90°C (-13 to +194°F)
 P2209 Head type: DIN form B
 (4-20mA output) Cable gland: PG 16
 Material: Grey enamelled aluminium
 Enclosure: IP 65
 Program. meas. range: -50 to +250°C (-58 to 482°F)
 Ambient temperature: -40 to +85°C (-13 to +185°F)
 Output signal /Supply: 4-20 mA – 8-35 VDC
 Load: ≤700 Ω @ 24VDC supply
 Linearity: ≤0,1%/FS.
 Temperature drift: ≤0,01%/°C

ORDERING INSTRUCTIONS

P2209	Connection	Immersion Length, L...
	Electrical connection	
	Temp. range (for P2209 with transmitter only)	
	Options	
eg.	P2209, 2" Tri-clamp, L50 mm, B-head, 0-100°C, Ra 0.5 µm	



Dimensions

P2209 with IEC 947-5-2 plug

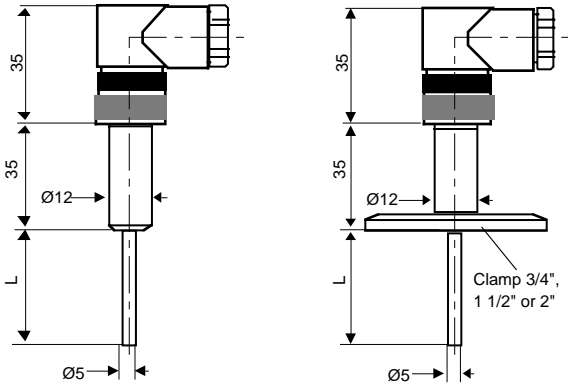

P2209 with PTFE cable

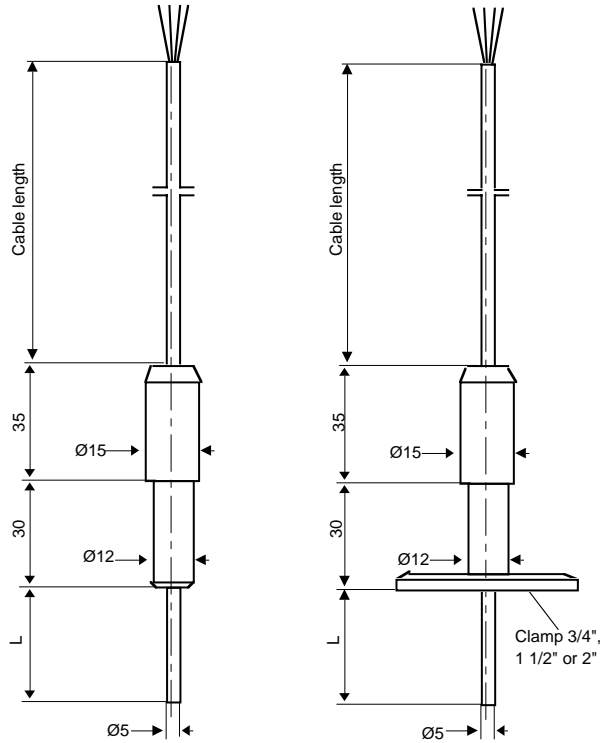

Electrical connection

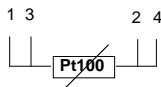

P2209 with built-in transmitter

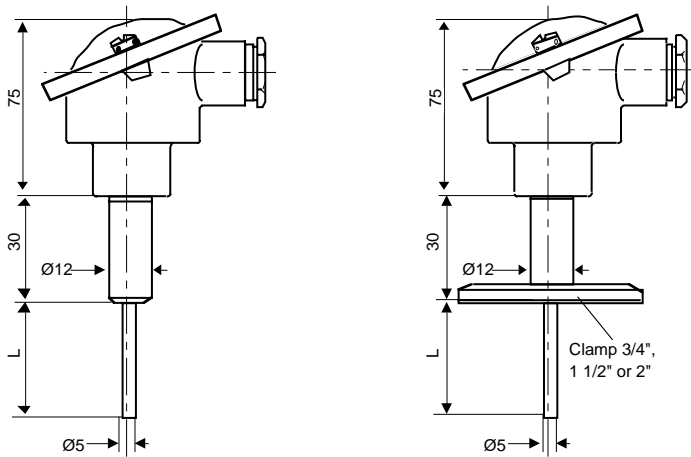

Electrical connection

